



REF. 1145

PTFE WAFER BUTTERFLY VALVE EXCELLENCE RANGE



Lloyd's Register
ISO 9001 : 2015



Lloyd's Register
PED/2014/68/EU



Certificate 3.1

Size : DN 32/40 to 300 mm
Ends : Between flanges PN10/16 and Class 150 (PN20)
Min Temperature : - 25°C
Max Temperature : + 200°C
Max Pressure : 16 Bars up to DN150
Specifications : Long neck for isolation
Wafer type
2 parts body
ISO 5211 mounting pad

Materials : Ductile iron EN GJS 500-7 body, PTFE seat

*the installation defects and wear defects are not covered by the guarantee

Internet : www.oktogonkft.hu | Webshop : webshop.oktogonkft.hu | e-mail: szolnok@oktogonkft.hu



REF. 1145

PTFE WAFER BUTTERFLY VALVE EXCELLENCE RANGE

SPECIFICATIONS :

- Long neck for isolation
- ISO 5211 mounting pad
- Wafer type
- Between flanges PN10/16 from DN32/40 to 300 and Class 150 (PN20) from DN40 to 300
- 2 parts body
- Full crossing stem
- PTFE sealing ring 3 mm thickness with silicone elastic gasket 6 mm thickness
- Stainless steel disc
- 9 positions lever with locking device up to DN200
- Rilsan coated body color RAL 5024 , 250-300 microns thickness
- Stem extension 75 mm length (option)
- Square lever 30x30 mm for special key (option)

USE :

- For corrosive fluids (acids ...)
- Min and max Temperature Ts : - 25°C to + 200°C
- Max Pressure Ps : 16 bars up to DN150, 10 bars over (see graph under)

RANGE :

- With lever from DN 32/40 to DN 200
- With IP65 gear box from DN 250 to DN 300 (possible from DN 32/40 to DN200 : **Ref. 1197**)
- On request , IP65 chain gear box (**Ref. 1194**) from DN 32/40 to DN 300
- On request , stem extension with special length (**Ref. 98665**)
- On request, stainless steel lever and bolting (**Ref. 9831250-9831264**)

PRESSURE / TEMPERATURE GRAPH (STEAM EXCLUDED) :

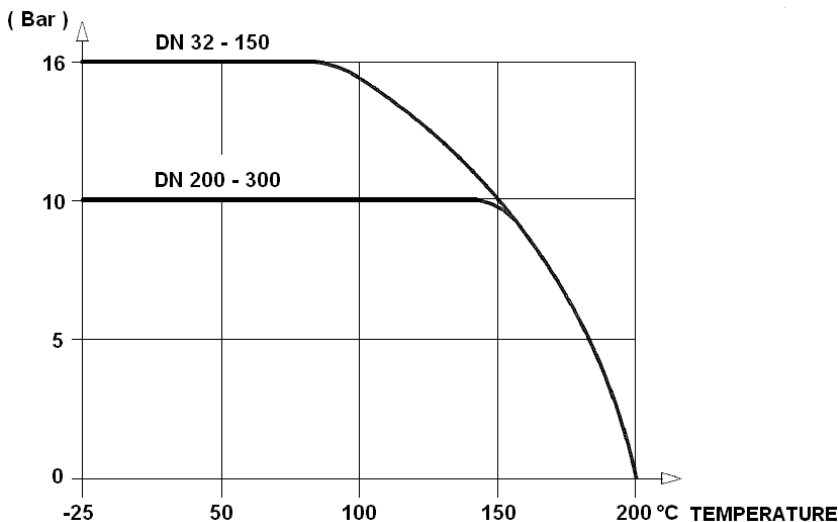

ENDS :

- Between flanges PN10/16 from DN32/40 to 300 and Class 150 (PN20) from DN40 to 300



REF. 1145

PTFE WAFER BUTTERFLY VALVE EXCELLENCE RANGE

TORQUE VALUES (in Nm with safety coefficient of 30 % included) at 10 Bars :

DN	32/40	50	65	80	100	125	150	200	250	300
Torque (Nm)	25	40	45	75	90	160	180	230	475	680

FLOW COEFFICIENT Kv (m3 / h) :

DN	Opening Angle								
	10°	20°	30°	40°	50°	60°	70°	80°	90°
32-40	3	5	10	16	22	31	36	36	36
50	3	7	15	33	44	48	54	54	54
65	6	10	21	40	57	86	102	102	102
80	7	16	37	56	84	182	246	246	246
100	9	22	51	88	134	187	255	336	336
125	21	33	91	153	232	331	468	560	560
150	45	69	149	281	302	597	822	1015	1072
200	55	131	254	420	631	904	1388	1758	1758
250	64	246	442	710	1056	1522	2128	3096	3096
300	100	275	472	953	1450	2093	2972	4193	4480

HEAD LOSS CALCULATIONS :

$\Delta p = (Q / Kv)^2 \times SG$

Q : flow in m³/h

Δp : Head loss in bar

SG : Specific gravity (= 1 for water)

Kv : Volume of water in m³/h, that will flow through a given restriction or valve opening with a pressure drop of 1 bar at 20°C)

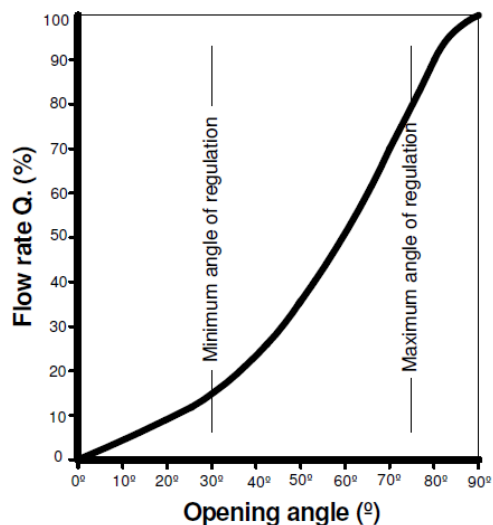

PTFE WAFER BUTTERFLY VALVE EXCELLENCE RANGE

MATERIALS :

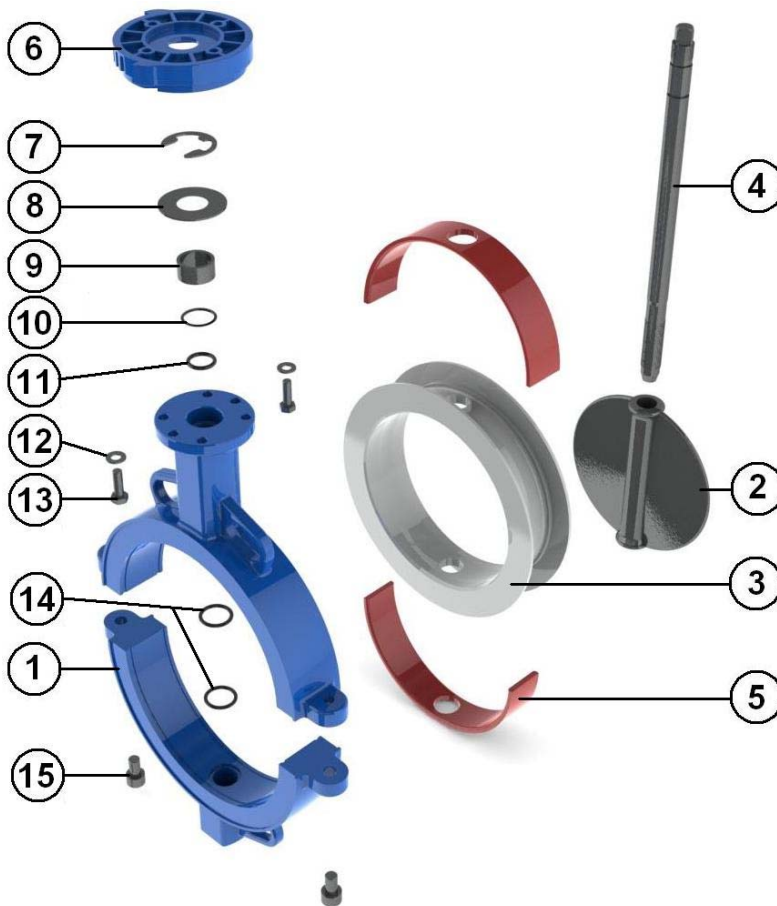

Item	Designation	Materials
1	Body	Ductile iron EN GJS-500-7 rilsan coated color RAL 5024 250-300 μ thickness
2	Disc	ASTM A351 CF8M
3	Seat	PTFE
4	Stem DN40-50 and 150-300	SS 17 4-PH (630)
4	Stem DN65-125	AISI 316
5	Insert	Silicone
6	Plate	Aluminium
7	Circlips	AISI 316
8	Ring	
9	Socket	
10	O ring	FKM
11	O ring	FKM
12	Washer	AISI 316
13	Plate screw	A4
14	O ring	FKM
15	Body screw	A4
	Lever	Aluminium ADC10 with epoxy painting 50μ thickness

PTFE WAFER BUTTERFLY VALVE EXCELLENCE RANGE

GEARBOX MATERIALS REF. 1197 :

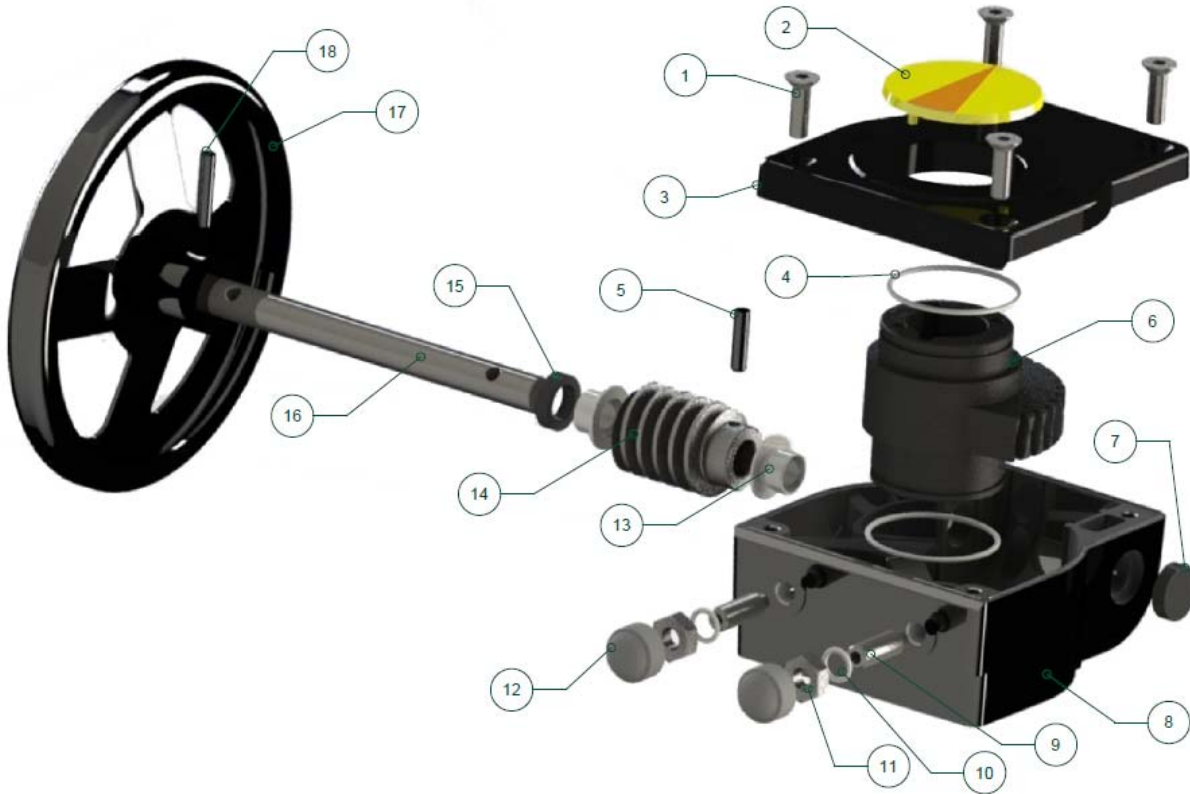

Item	Designation	Materials Ref. 1197
1	Screw	AISI 304
2	Indicator	Polypropylene
3	Cover	Aluminium
4	O ring	NBR
5	Pin	Carbon steel
6	Quadrant	Ductile iron EN GJS-400-15
7	Gasket	NBR
8	Body	Aluminium
9	Adjusting bolt	Carbon steel
10	Washer	Galvanized steel
11	Nut	Galvanized steel
12	Cap	NBR 70
13	Bushing	Bronze
14	Worm	Carbon steel 45
15	Gasket	NBR
16	Shaft	Carbon steel 45
17	Handwheel	Carbon steel
18	Pin	Carbon steel

PTFE WAFER BUTTERFLY VALVE EXCELLENCE RANGE

SIZE (in mm) :

- Valves :

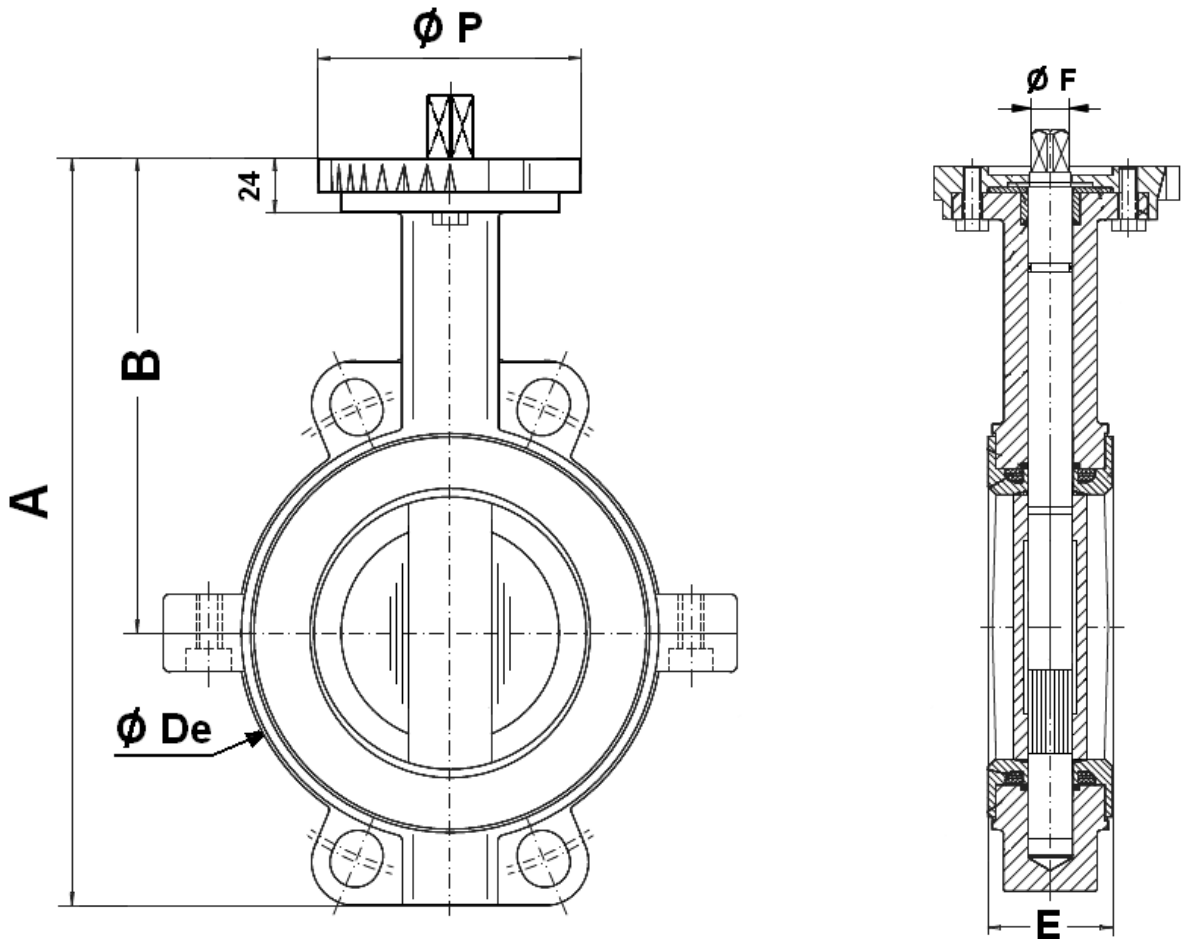

DN	32/40	50	65	80	100	125	150	200	250	300
A	205	226	242	262	290	326	348	438	448	515
B	140	156	161	167	184	207	215	257	248	280
Ø De	83	103	117	134	150	185	205	270	320	373
E	33	43	46	46	52	56	56	60	68	78
Ø F	9.5	9.5	12	14	14	17	17	21	23	26.5
Ø P	88	88	88	88	88	105	105	105	150	150
Weight (Kg)	2.5	4	4.57	5.18	6.5	9.5	10.37	16.8	31	42

PTFE WAFER BUTTERFLY VALVE EXCELLENCE RANGE

STANDARD LEVERS SIZE (in mm) :

DN 32 – 200 :

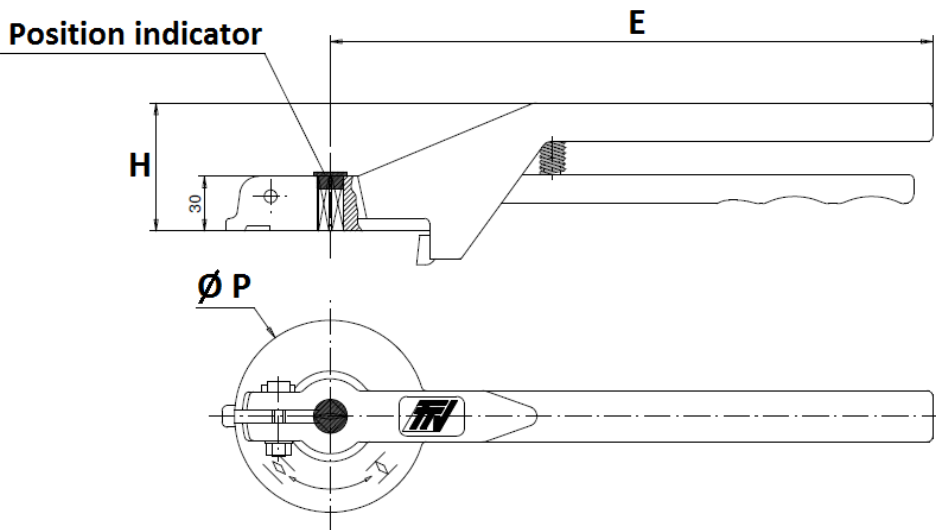

DN	32-100	125-200
E	205	330
H	57	70
Ø P	88	105

PTFE WAFER BUTTERFLY VALVE EXCELLENCE RANGE

ASTM A351 CF8M STAINLESS STEEL LEVERS SIZE (in mm) (ON REQUEST) :

DN 40 - 100

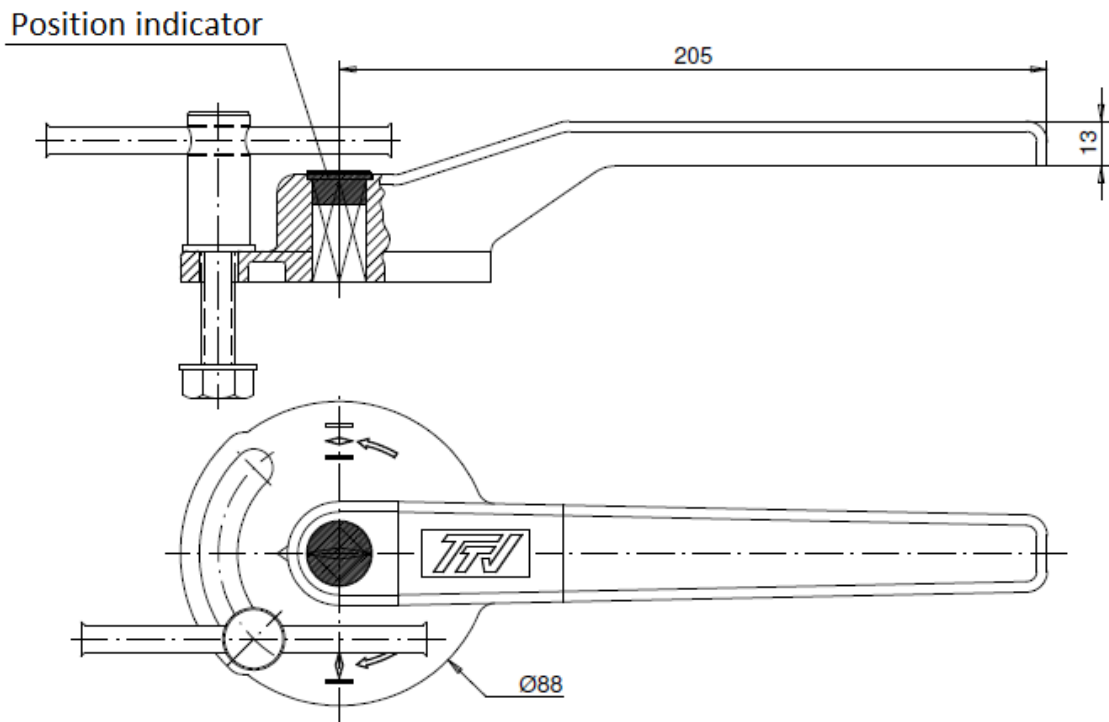

DN 125 - 200

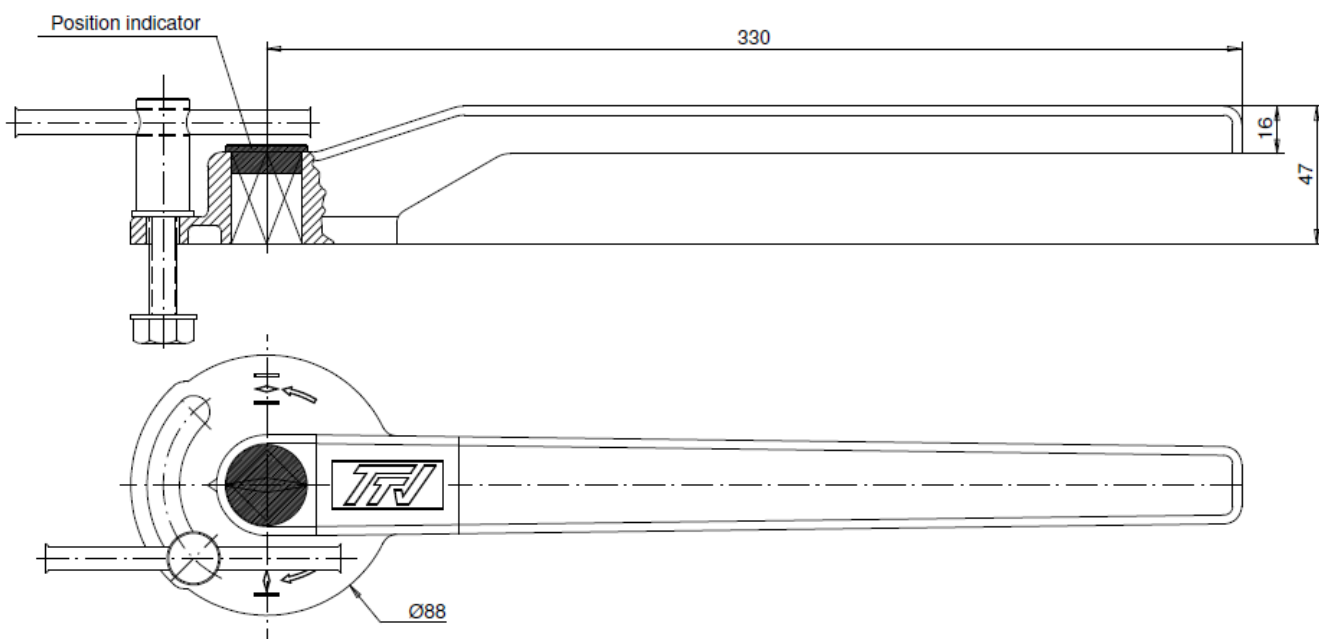

PTFE WAFER BUTTERFLY VALVE EXCELLENCE RANGE

ISO MOUNTING PAD AND STEM SIZE (in mm) :

DN 40 - 200

DN 250 – 300

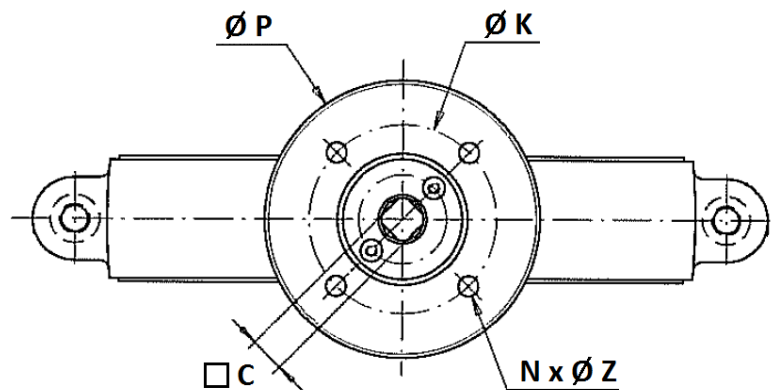
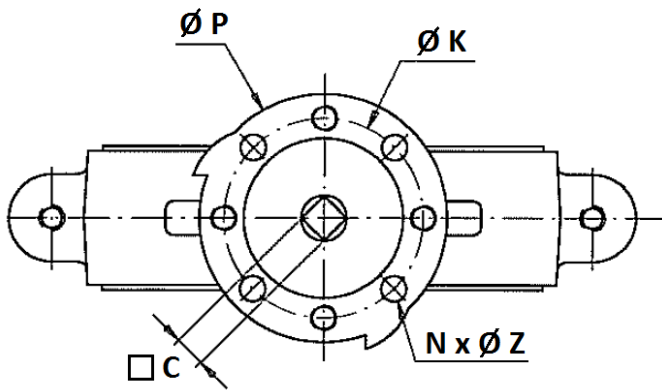
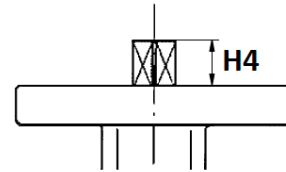
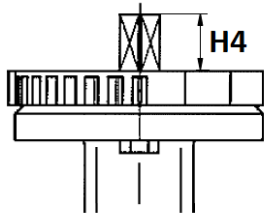

DN	32/40	50	65	80	100	125	150	200	250	300
H4	14	14	16	16	20	20	20	24	24	24
C	8	8	9	11	11	14	14	17	19	22
Ø K	70	70	70	70	70	70	70	70	102	102
ISO	F07	F07	F07	F07	F07	F07	F07	F07	F10	F10
N x Ø Z	4 x 9	4 x 9	4 x 9	4 x 9	4 x 9	4 x 9	4 x 9	4 x 9	4 x 11	4 x 11
Ø P	88	88	88	88	88	105	105	105	150	150

PTFE WAFER BUTTERFLY VALVE EXCELLENCE RANGE

SIZE (in mm) :

- Valves with gear box :

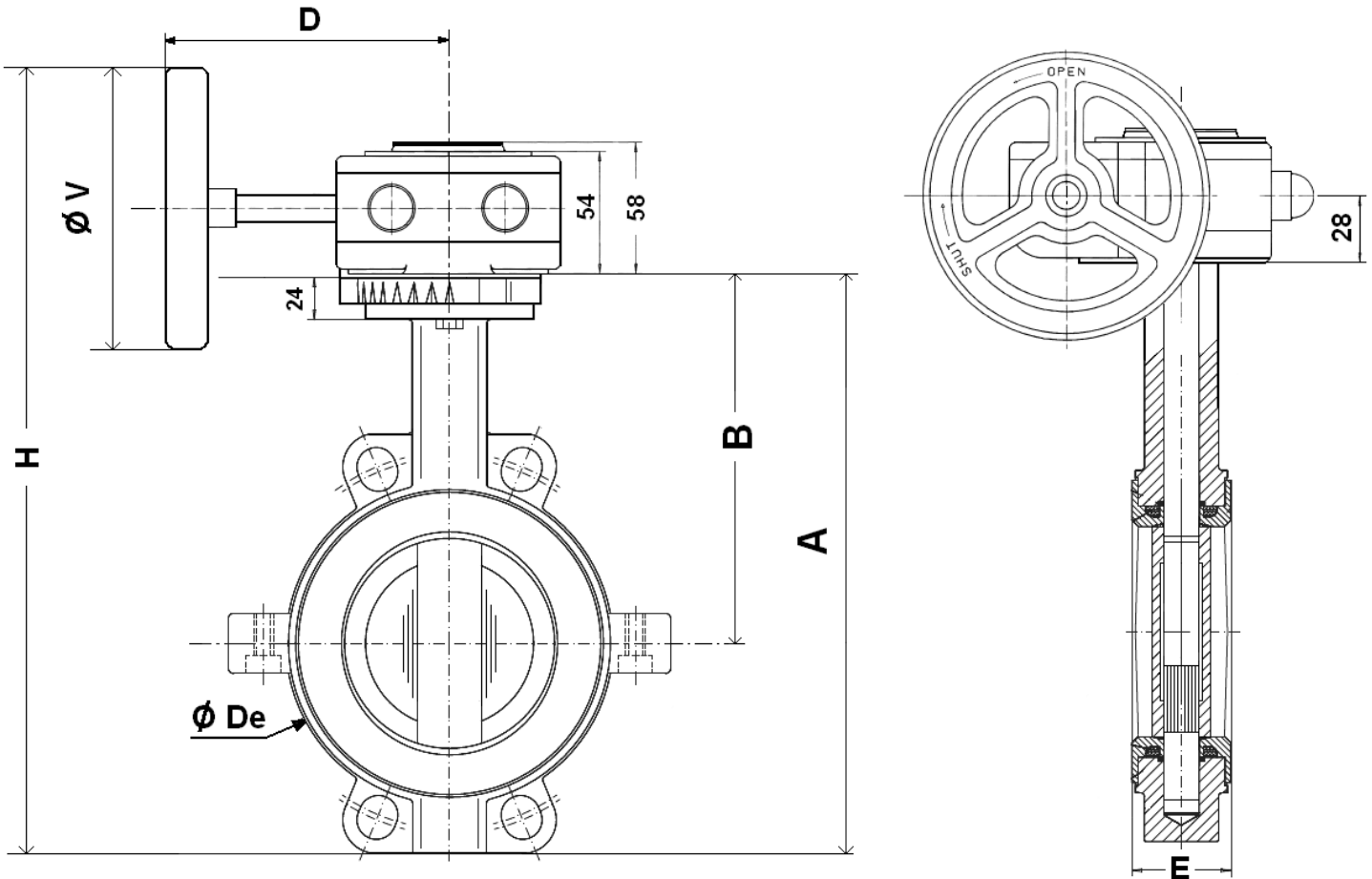

DN	32/40	50	65	80	100	125	150	200	250	300
A	205	226	242	262	290	326	348	438	448	515
B	140	156	161	167	184	207	215	257	248	280
Ø De	83	103	117	134	150	185	205	270	320	373
D	120	120	120	120	120	136	136	136	223	223
E	33	43	46	46	52	56	56	60	68	78
H	304	326	341	364	392	452	477	566	634	701
Ø V	140	140	140	140	140	200	200	200	300	300
Poids (en Kg)	3.85	5.35	5.92	6.53	7.85	11.25	12.12	18.55	35	46

PTFE WAFER BUTTERFLY VALVE EXCELLENCE RANGE

SIZE (in mm) :

- Valves with chain gear box :

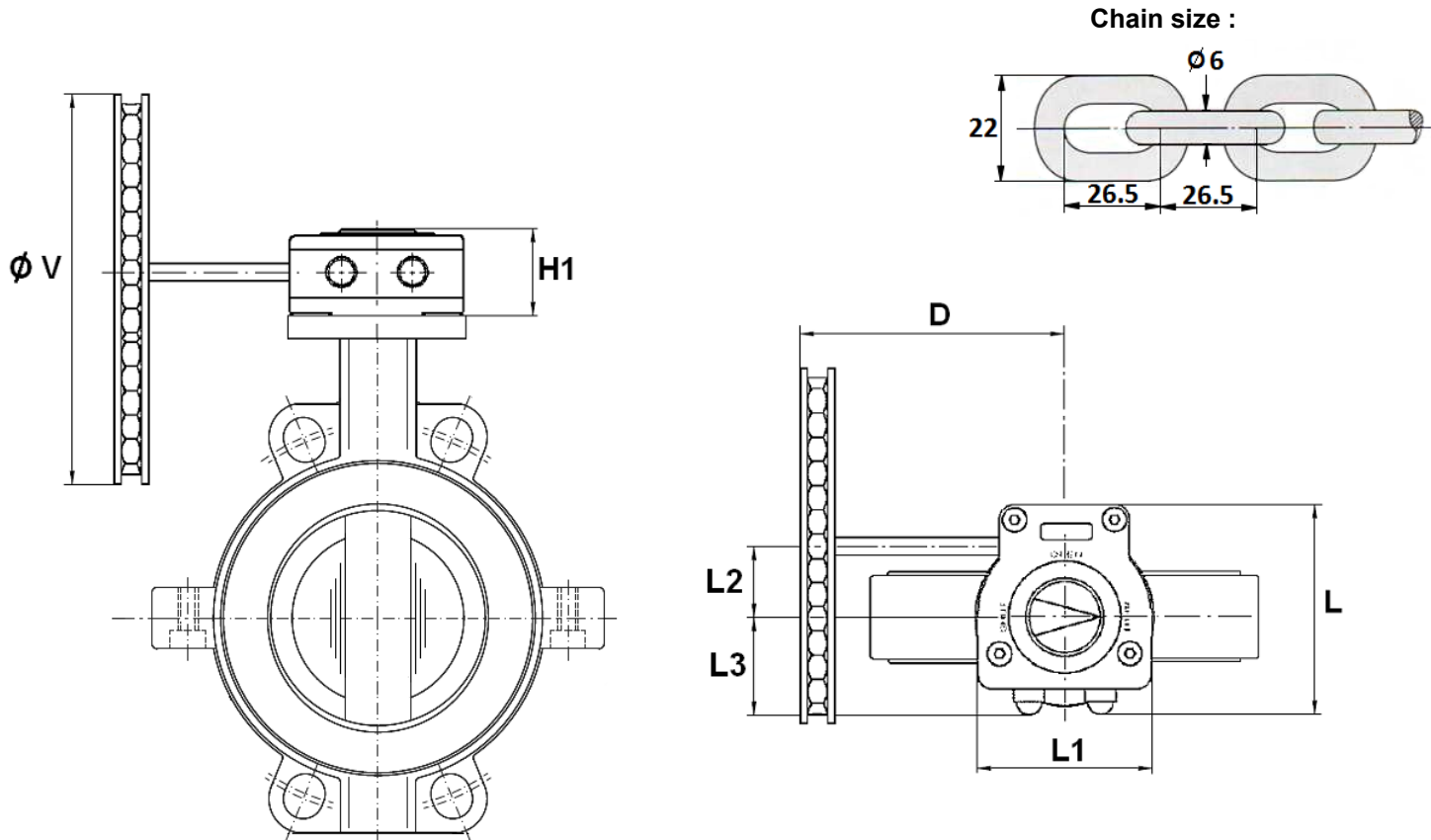

DN	32/40	50	65	80	100	125	150	200	250	300
D	120	120	120	120	120	126	126	126	214	214
H1	58	58	58	58	58	58	58	58	74	74
L	128	128	128	128	128	128	128	128	175	175
L1	100	100	100	100	100	100	100	100	142	142
L2	50	50	50	50	50	50	50	50	61	61
L3	56	56	56	56	56	56	56	56	80	80
Ø V	160	160	160	160	160	210	210	210	300	300
Weight (Kg)	4.85	6.35	6.92	7.53	8.85	12.25	13.12	19.55	37.8	48.8

PTFE WAFER BUTTERFLY VALVE EXCELLENCE RANGE

GEARBOX SPECIFICATIONS :

DN	32/50	65	80/100	125/150	200	250	300
Ref.	1197050	1197065	1197100	1197150	1197200	1197250	1197300
Ratio factor	37 : 1	37 : 1	37 : 1	37 : 1	37 : 1	36 : 1	36 : 1
Number of cycles for opening or closing	9.25	9.25	9.25	9.25	9.25	9	9
Input torque (Nm)	12.5	12.5	12.5	12.5	12.5	23	23
Output torque (Nm)	300	300	300	300	300	675	675

DISC AND NECK SIZE (in mm) :

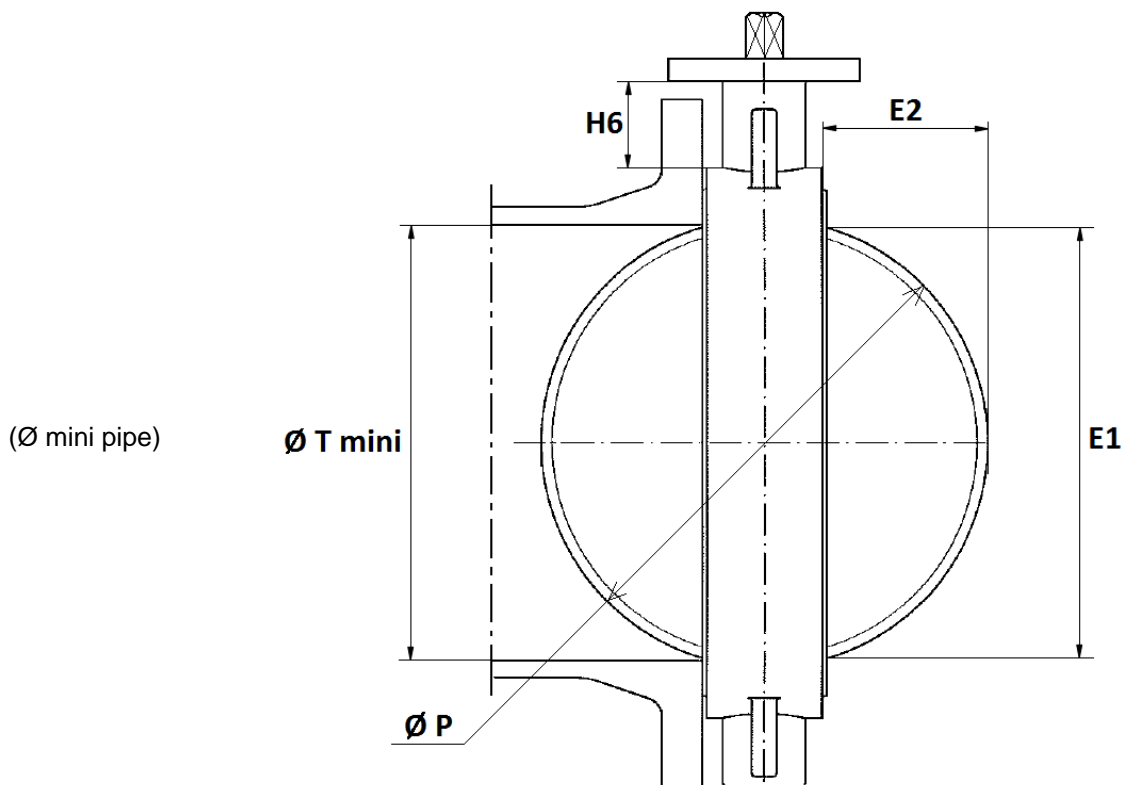

DN	32/40	50	65	80	100	125	150	200	250	300
E1	23	24.5	46	65	85	109	136	188	238	289
E2	3.5	3.5	9.5	17	24	33.5	45.5	69	90	110.5
H6	76	82	80	80	88	93	89	99	71	76
Ø T mini	26	27.5	49	68	88	112	139	191	241	292
Ø P	40	50	65	80	100	123	147	198	248	299

PTFE WAFER BUTTERFLY VALVE EXCELLENCE RANGE

SIZE (in mm) :

- Square lever for special key (30x30 mm) :

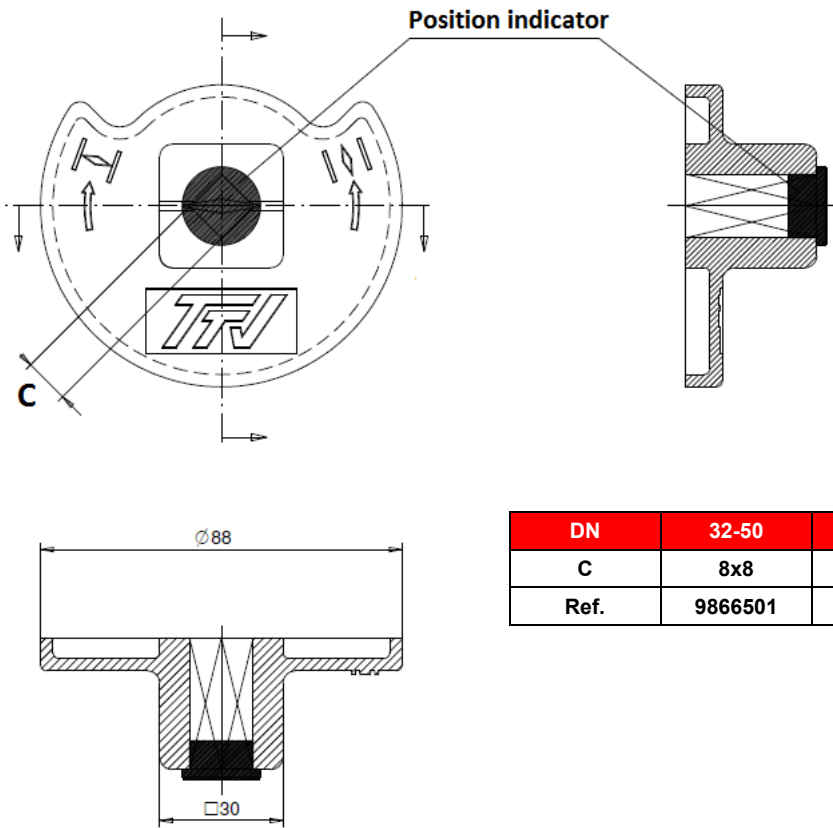

DN	32-50	65	80-100	125-150	200
C	8x8	9x9	11x11	14x14	17x17
Ref.	9866501	9866502	9866503	9866504	9866505

PTFE WAFER BUTTERFLY VALVE EXCELLENCE RANGE

BETWEEN FLANGES SIZE (in mm) :

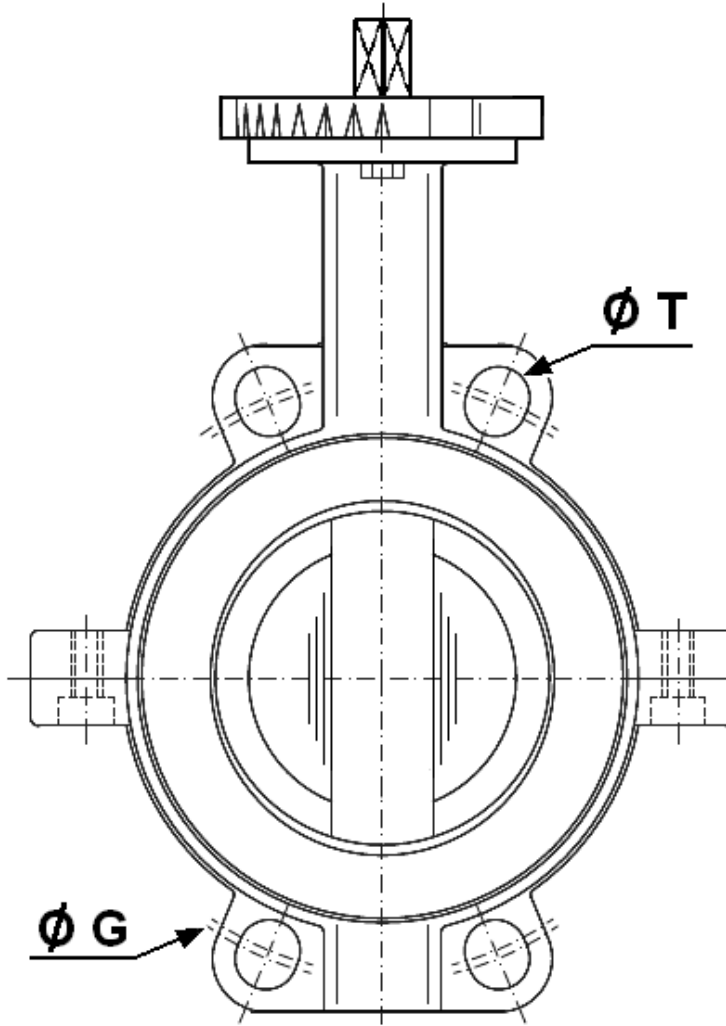

	DN (mm)	32	40	50	65	80	100	125	150	200	250	300
	NPS (")	1"1/4	1"1/2	2"	2"1/2	3"	4"	5"	6"	8"	10"	12"
PN10	Ø G	100	110	125	145	160	180	210	240	295	350	400
	Ø T	18	18	18	18	18	18	18	23	23	23	23
PN16	Ø G	100	110	125	145	160	180	210	240	295	355	410
	Ø T	18	18	18	18	18	18	18	23	23	27	27
Class 150	Ø G	88.9	98.5	120.6	139.7	152.4	190.5	215.9	241.3	298.5	362	431.8
	Ø T	16	16	19	19	19	19	23	23	23	26	26



REF. 1145

PTFE WAFER BUTTERFLY VALVE EXCELLENCE RANGE

STANDARDS :

- Fabrication according to ISO 9001:2015
- Designing according to ISO 10631 and EN 593
- DIRECTIVE 2014/68/EU : CE N° 0038
Risk Category III module H
- Certificate 3.1 on request
- Tests according to EN 12266-1, Rate A
- Between flanges according to EN 1092-1 PN10/16
- ISO 5211 mounting pad
- Length according to ISO 5752 short series 20, EN 558 series 20 (NF 29305),BS 5155 Wafer short/medium, DIN 3202 part 3, series K1
- ATEX Group II Category 2 G/2D Zone 1 & 21 Zone 2 & 22 (optional marking)
- **FDA PTFE** seat
- PTFE seat compatible with foodstuffs according to the rule **CE 1935/2004 (article 3)**

ADVICE : Our opinion and our advice are not guaranteed and SFERACO shall not be liable for the consequences of damages.

The customer must check the right choice of the products with the real service conditions.

PTFE WAFER BUTTERFLY VALVE EXCELLENCE RANGE

INSTALLATION INSTRUCTIONS

GENERAL GUIDELINES :

- Ensure that the valves to be used are appropriate for the conditions of the installation (type of fluid, pressure and temperature).
- Be sure to have enough valves to be able to isolate the sections of piping as well as the appropriate equipment for maintenance and repair.
- Ensure that the valves to be installed are of correct strength to be able to support the capacity of their usage.
- **Installation of all circuits should ensure that their function can be automatically tested on a regular basis (at least two times a year).**

INSTALLATION INSTRUCTIONS :

- **Before installing the valves, clean and remove any objects from the pipes** (in particular bits of sealing and metal) which could obstruct and block the valves.
- **Ensure that both connecting pipes either side of the valve (upstream and downstream) are aligned (if they're not, the valves may not work correctly).**
- **Make sure that the two sections of the pipe (upstream and downstream) match, the valve unit will not absorb any gaps. Any distortions in the pipes may affect the tightness of the connection, the working of the valve and can even cause a rupture.** To be sure, place the kit in position to ensure the assembling will work.
- **If sections of piping do not have their final support in place, they should be temporarily fixed. This is to avoid unnecessary strain on the valve.**
- The valve must be inserted between flanges with disc half opened but the disc must not overpass the valve thickness. Position the bolts to keep centered the valve. Then open fully the valve and tighten the bolts.
See graph under.

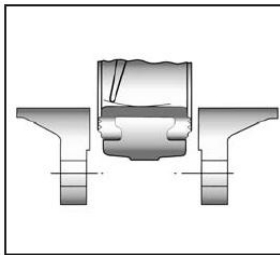

Half open valve introduction

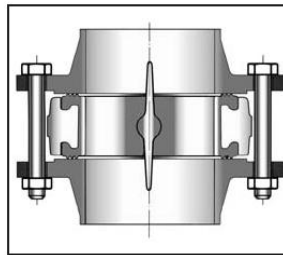

Complete opened disc valves when screw tightening

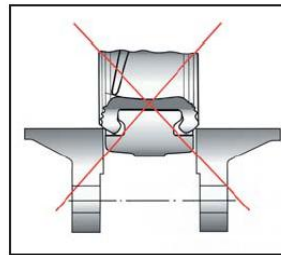

- Tighten the bolts in cross.
- The disc must move easily inside the pipe.
- Valves must be opened during cleaning operation.
- Tests must be done with a cleaned pipe.
- Tests must be done with opened valve. Test pressure must not be higher than the valve specification according to ISO 5208.
- Then open slowly the valve.
- **Do not mount butterfly valves with stainless steel pressed collars and turning flanges without strias.**
- **And not on flat face flanges without strias (example : painted cast iron fittings)**

PTFE WAFER BUTTERFLY VALVE EXCELLENCE RANGE

MAXIMUM TIGHTENING TORQUES FOR BOLTING FLANGES :

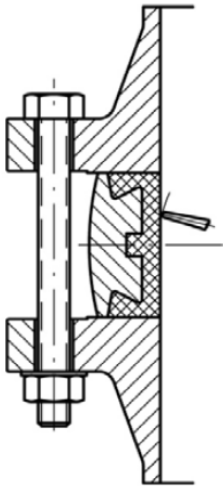

		Maximum torques (Nm)			
		5,6 / A307 Gr.B	8,8 / A193 B7	10,9	12,9
Bolting DN	Bolting types				
	M12 (1/2")	41,16	84,28	117,6	142,1
	M14 (9/16")	66,64	132,3	186,2	225,4
	M16 (5/8")	102,9	205,8	289,1	347,9
	M18 (3/4")	142,1	284,2	396,9	475,3
	M20 (3/4")	196	401,8	568,4	676,2
	M22 (7/8")	259,7	539	764,4	911,4
	M24 (1")	338,1	695,8	980	1176
	M27 (1"1/8)	499,8	1029	1470	1764
M30 (1"1/4)	666,4	1421	1960	2352	

BEST POSITION INSTALLATION :

For wastewater, fluids with solid particles or cold network (air conditioning for example), the best position is the horizontal one :

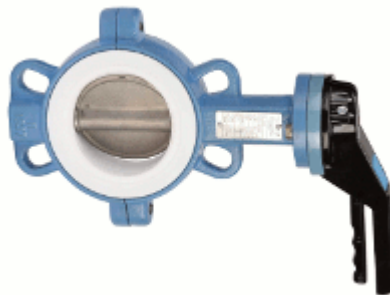

MAINTENANCE :

- We recommend to operate fully the valve 1 to 2 times per year.
- During maintenance operation, ensure that the pipe isn't under pressure, that there's no fluid in the pipe and that the valve is isolated. If there's a fluid in the pipe , evacuate it. Ensure that there are no risks due to the temperature or the fluid (like acids). If the fluid is corrosive , inert the installation before maintenance operation.